

PARTS LIST

ITEM	PART	DESCRIPTION	QTY
1	42326	TUBE 1/8 X 2 X 2 - 42	4
2	42330	FOOT- PURCHASED	4
3	42333	TUBE 1/8 X 2 X 2 - 30	2
4	42334	TUBE 1/8 X 2 X 2 - 24	5
5	42335	TUBE 1/8 X 2 X 2 - 32	2
6	42348	TUBE 1/8 X 2 X 2 - 14	2

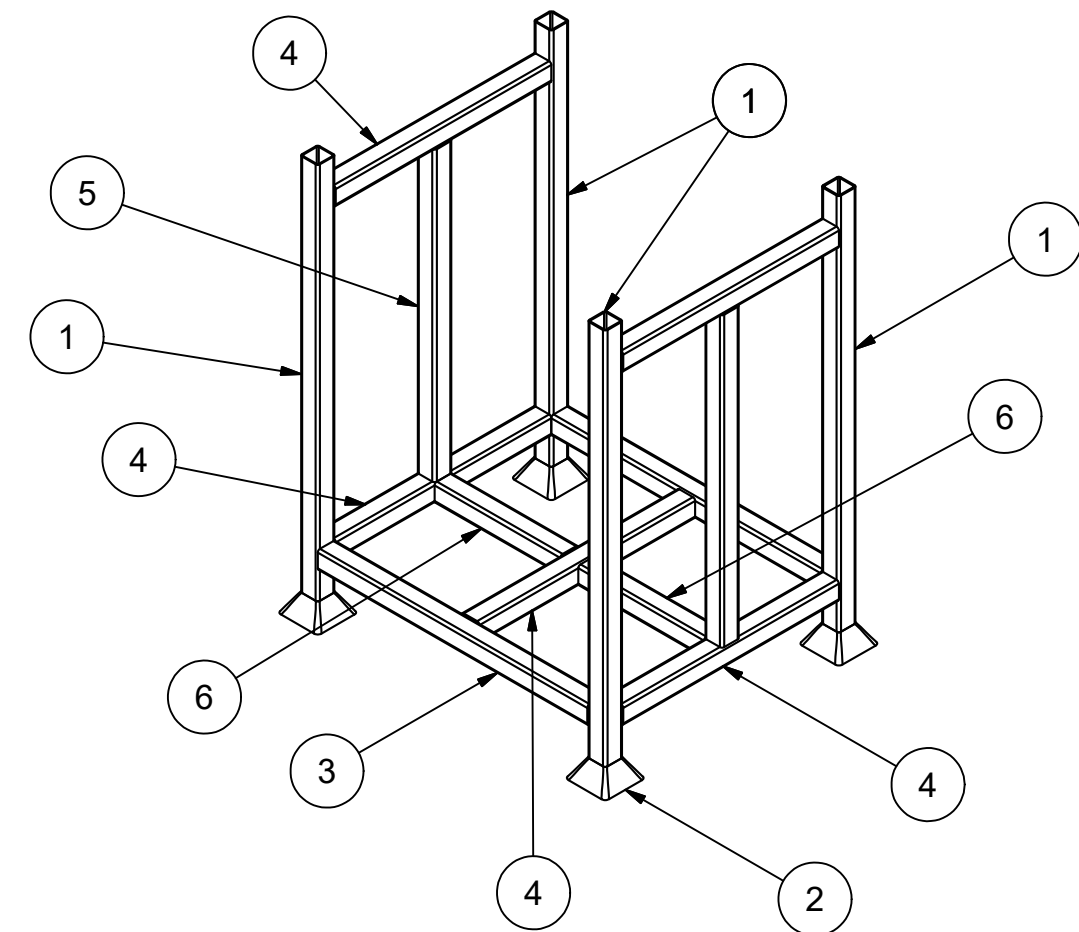

PROPERTY OF PALLET REPAIR SYSTEMS INC. JACKSONVILLE IL AND IS LOANED TO THE RECIPIENT SUBJECT TO RETURN UPON DEMAND. IT'S CONTENTS ARE CONFIDENTIAL AND MUST NOT BE COPIED OR SUBMITTED TO OUTSIDE PARTIES FOR USE OR EXAMINATION.

UNLESS OTHERWISE SPECIFIED
 DIM TOLERANCE: INCHES
 ONE PLACE: +/- .15
 TWO PLACES: +/- .010
 THREE PLACES: +/- .005
 () INDICATES REF DIM

QTY: 30
 STOCK #: PRSLRA101
 NEXT ASSY:

MATERIAL: WELDMENT SCALE: NTS

DRAWN BY: TDL DATE: 10-19-23

DESCP: LUMBER RACK (28 X 34)

SHEET NO: 1 OF 1 PART NO: LRA-101 REV: A